

The Atomic Nucleus

Discovery of Radioactivity

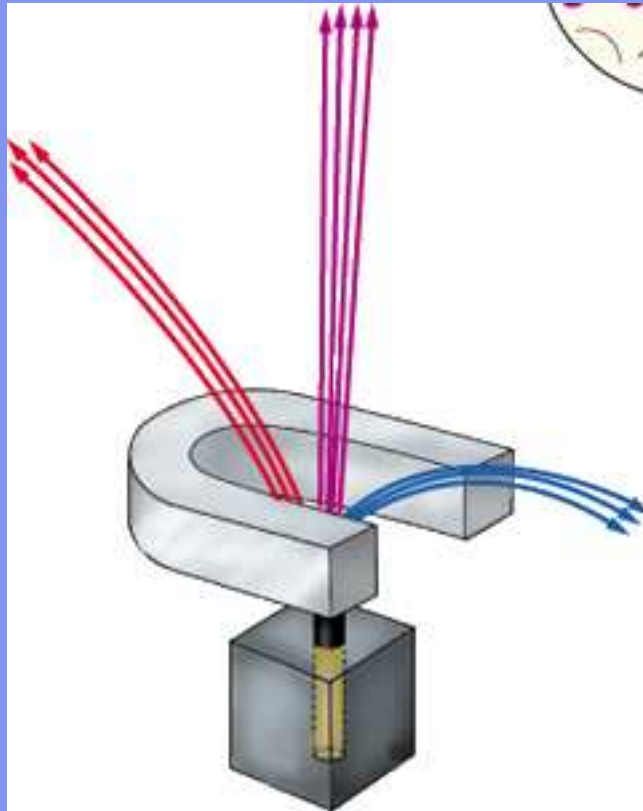

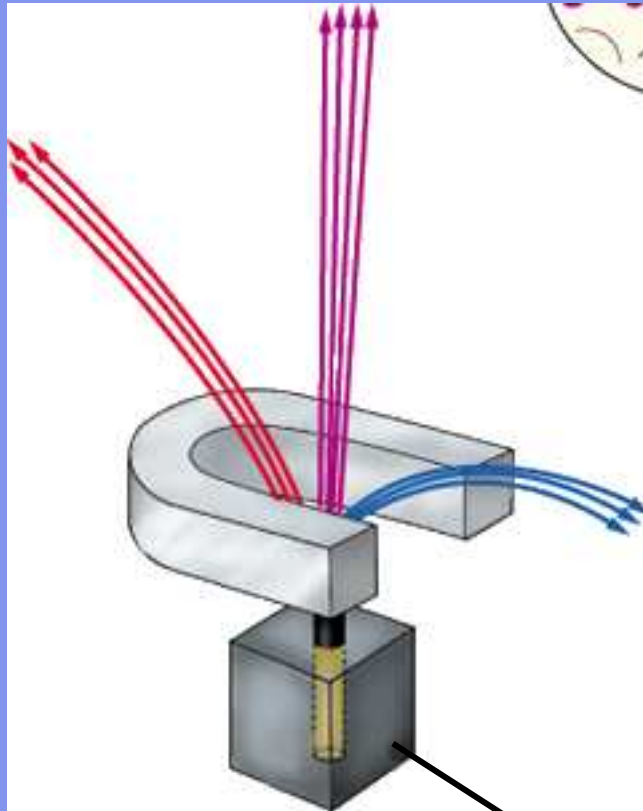

Lead block

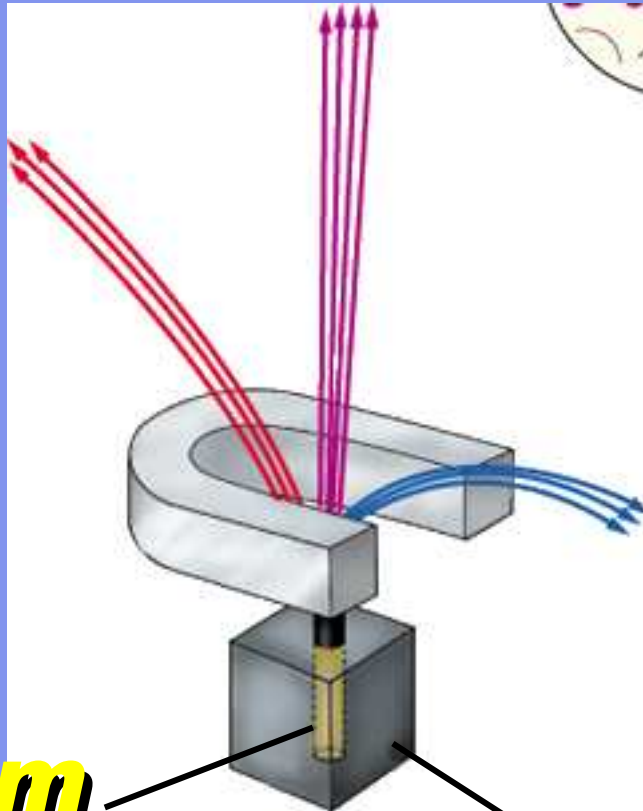

Radium

Lead block

Magnet

Radium

Lead block

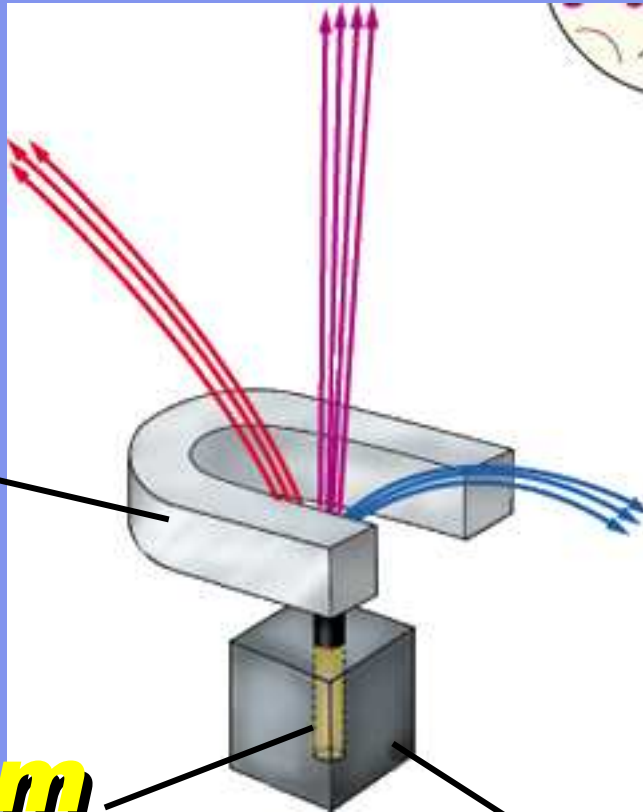

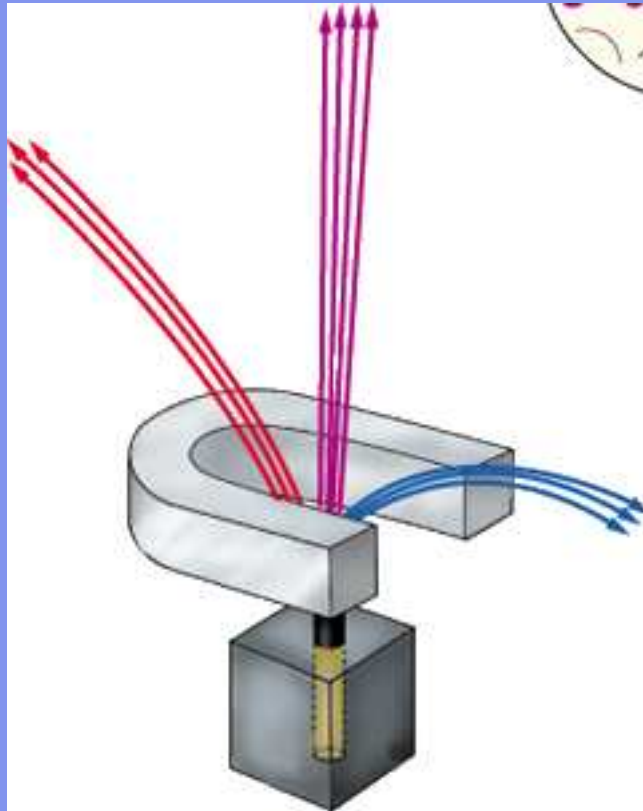

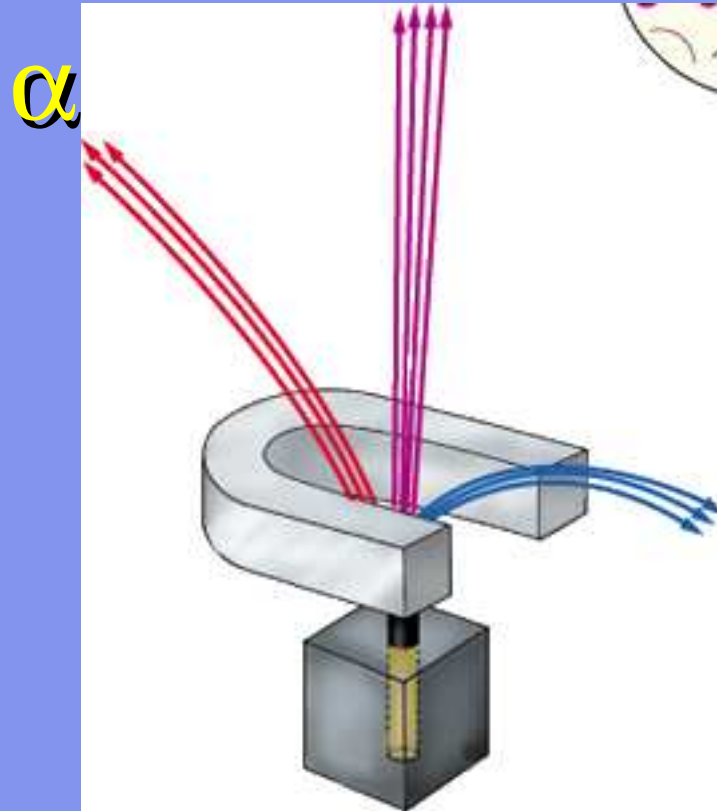



α

**Alpha particle
(helium nucleus)**

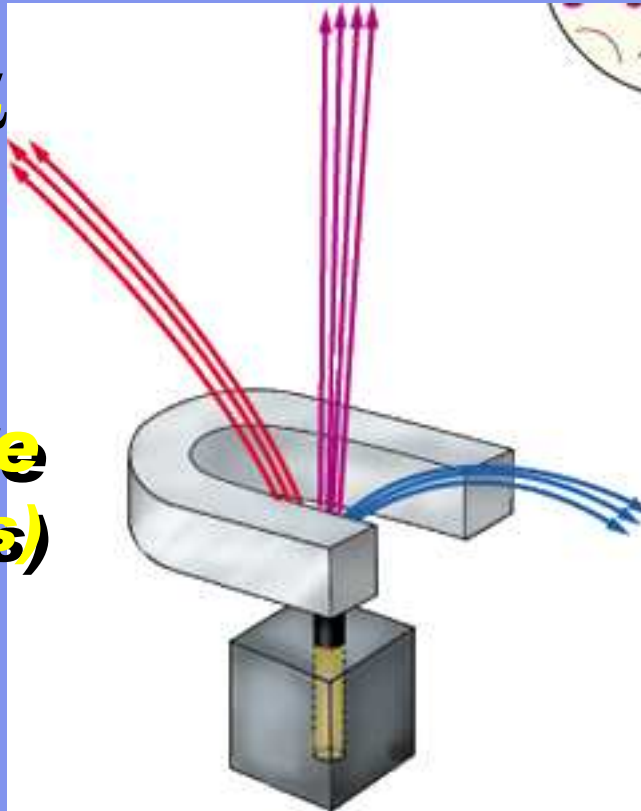

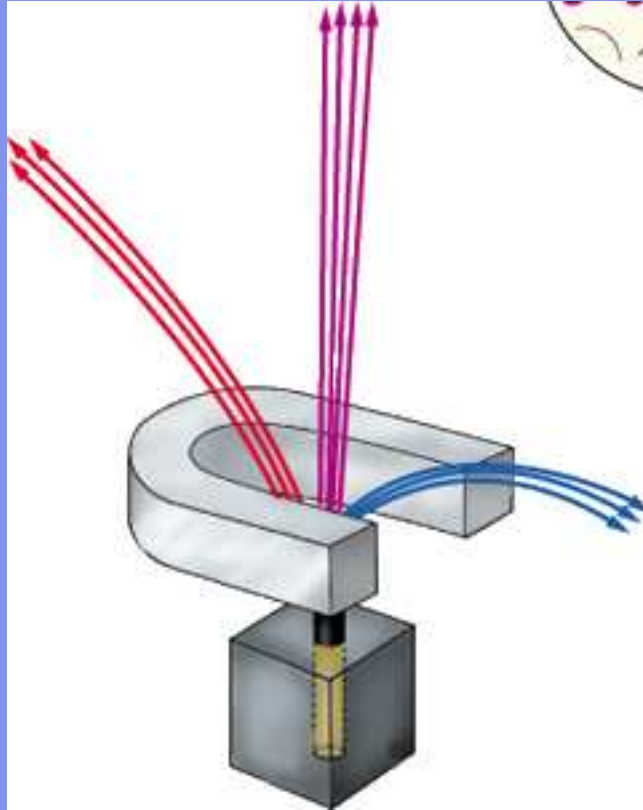

β

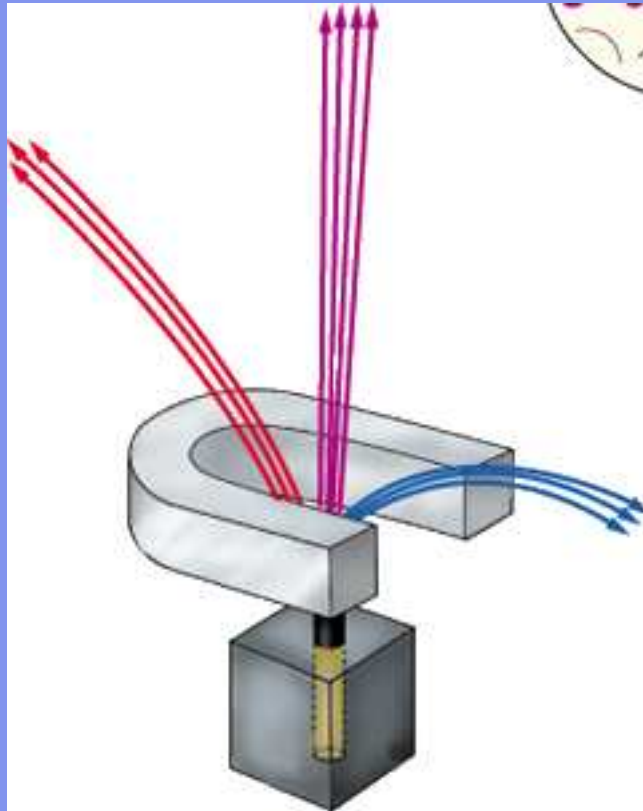

β



**Beta particle
(electron)**

γ

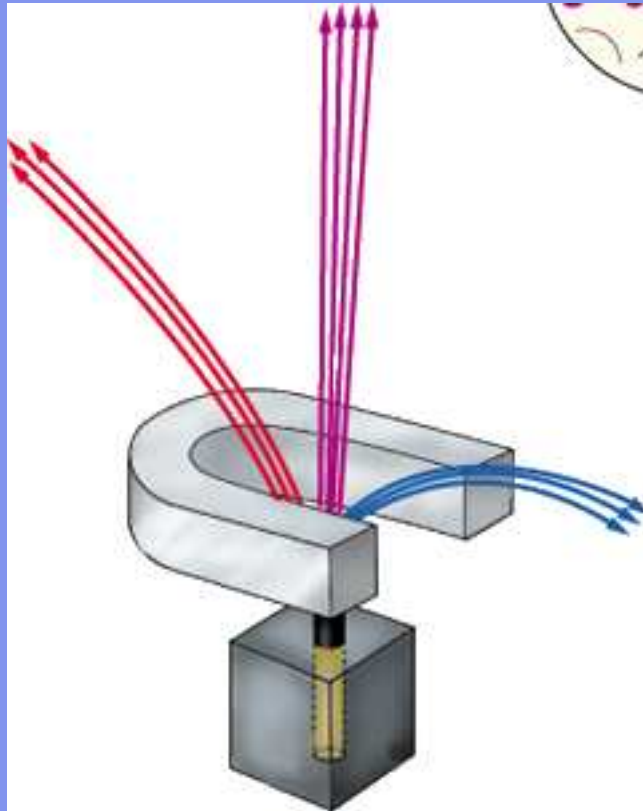

γ



Gamma ray
(ultra-high energy
nonvisible light)

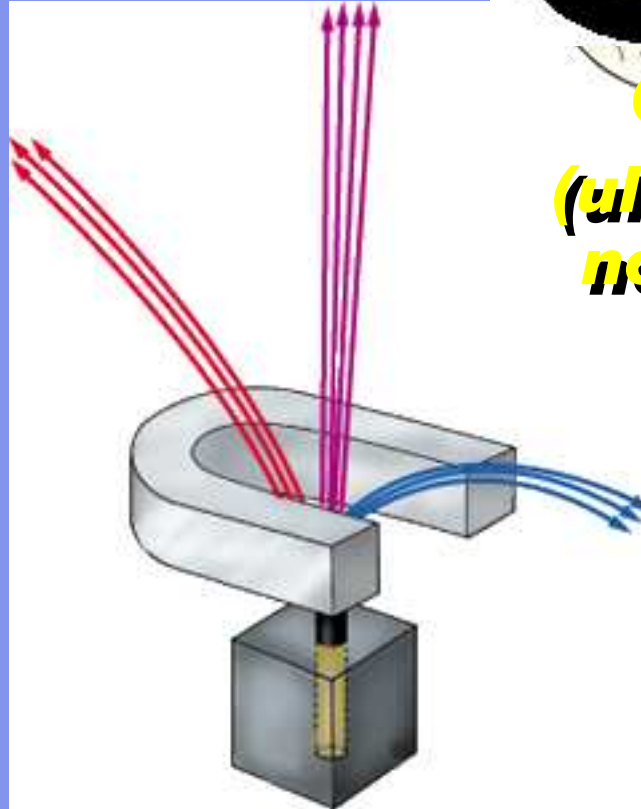

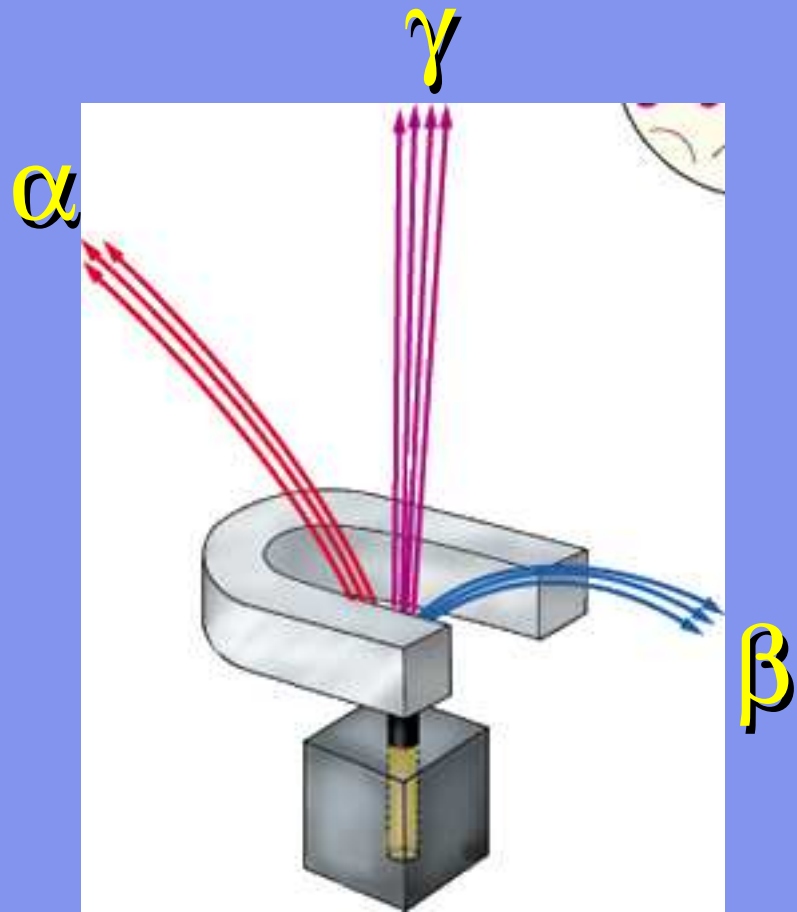

**Radioactive
Source**

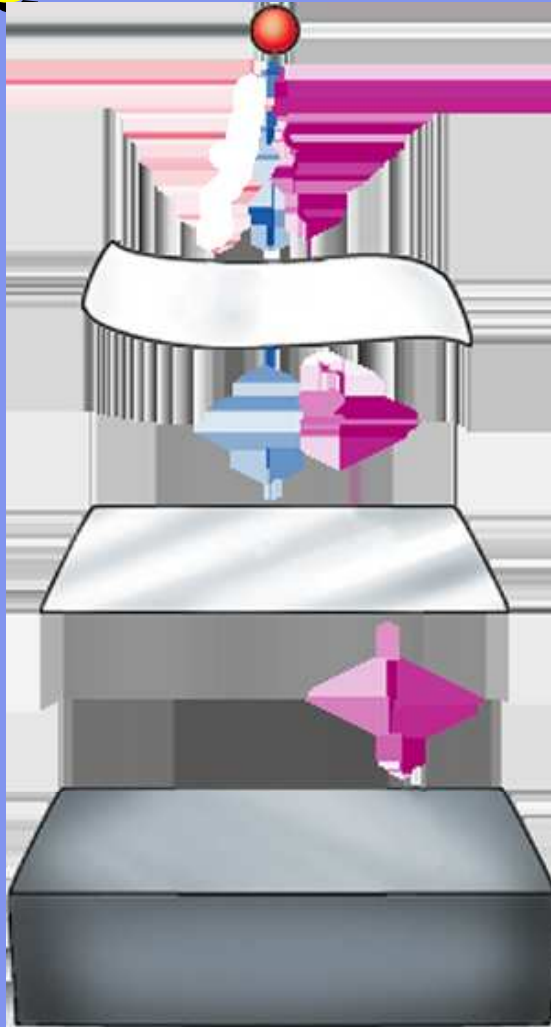

Paper

Aluminum

Lead

**Radioactive
Source**

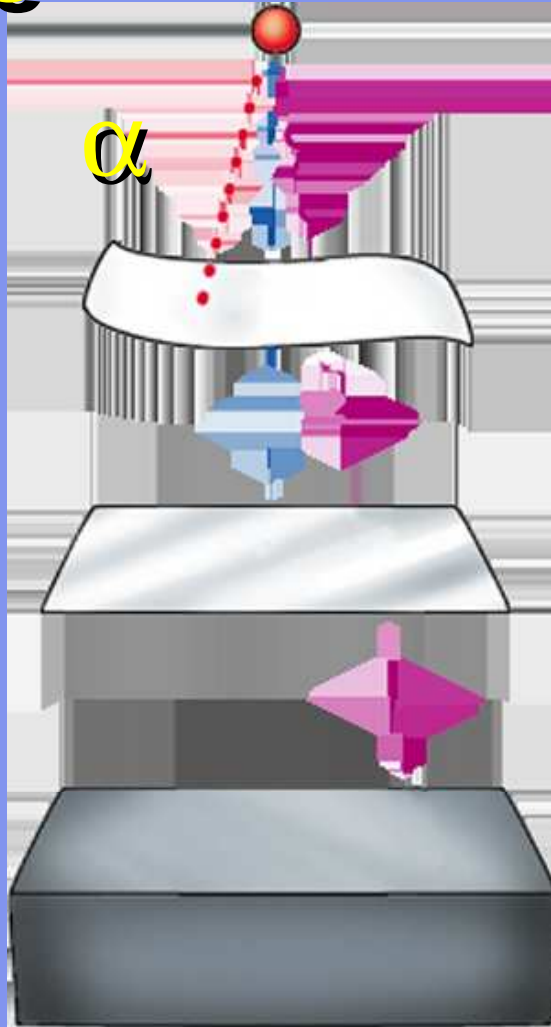

Paper

Aluminum

Lead

**Radioactive
Source**

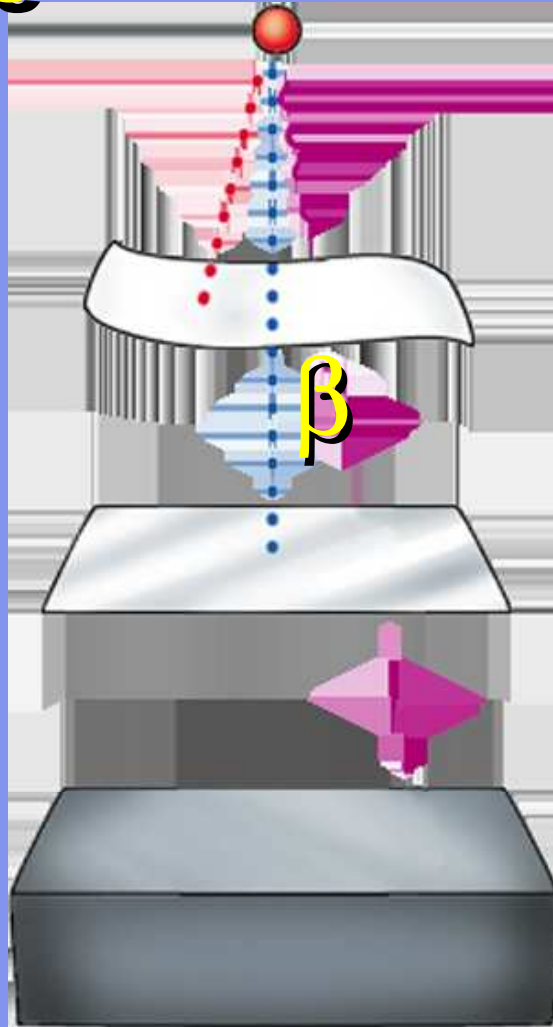

Paper

Aluminum

Lead

Radioactive Source

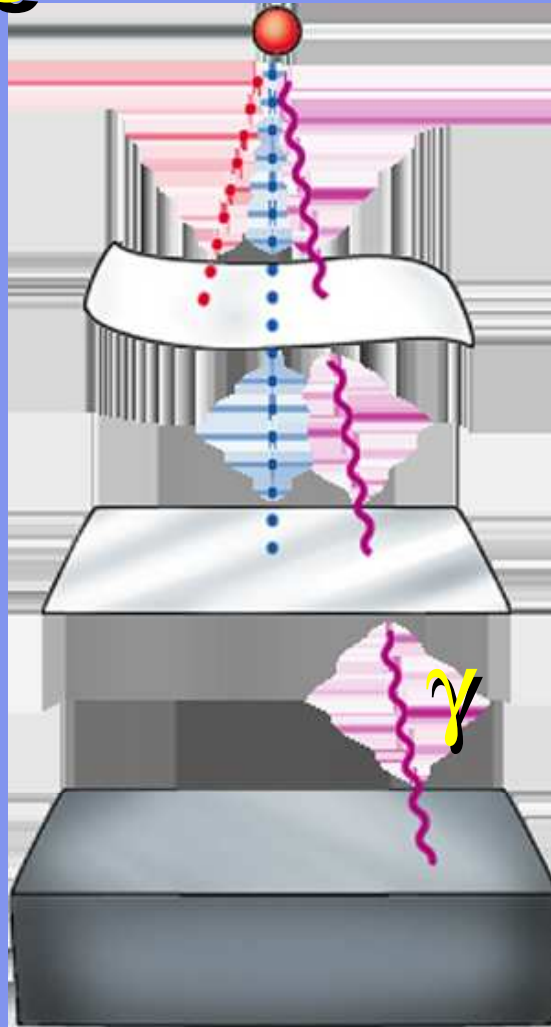

Paper

Aluminum

Lead

Radioactivity Is a Natural Phenomenon

Origins of radiation exposure

Origins of radiation exposure

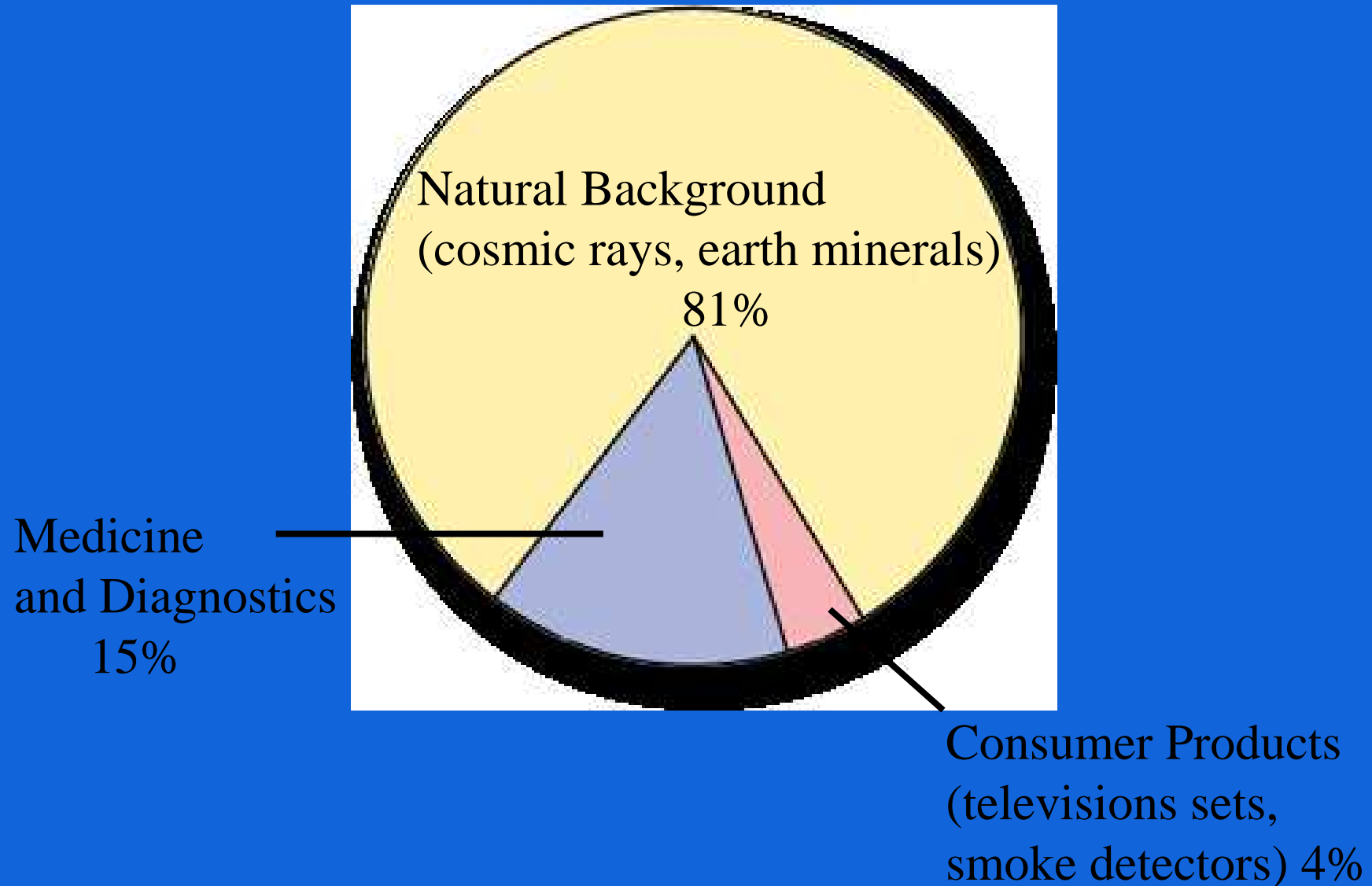

Unit of radiation exposure

Unit of radiation exposure

rad

Unit of radiation exposure

$$\mathbf{rad} = \frac{\mathbf{0.01\ joule\ radiant\ energy}}{\mathbf{kilogram\ of\ tissue}}$$

***Some forms of radiation
are more harmful to
living organisms than
others...***

***Ability to cause harm
is given in “rem”***

rem = rad x factor

Particle

Dosage

Factor

***Health
effect***

Particle

Dosage

Factor

**Health
effect**

alpha

1 rad

x 10

=

10 rem

<u>Particle</u>	<u>Dosage</u>	<u>Factor</u>	<u>Health effect</u>
alpha	1 rad	x 10	= 10 rem
beta	10 rad	x 1	= 10 rem

1 rem = 1000 millirem
(mrem)

***Average annual
exposure per person
In the United States***

about 360 mrem

Major Source
Radon - 222

Typical Annual Radiation Exposure

Source

Natural Origin

**Typical Amount
Received in 1 Year
(millirems)**

Cosmic radiation	26
Ground	33
Air (radon-222)	198
Human tissues (potassium-40; radium-226)	35

Human Origin

Medical procedures	
Diagnostic X rays	33
Nuclear medicine	15
Television tubes, other consumer products	11
Weapons-test fallout	1

**Radioactive Isotopes Are Useful
as Tracers
and for Medical Imaging**

Uses of Some Radioactive Isotopes

<i>Isotope</i>	<i>Usage</i>
Calcium-47	Study of bone formation in mammals
Californium-252	Inspect airline luggage for explosives
Hydrogen-3 (tritium)	Life-science and drug-metabolism studies to ensure safety of potential new drugs
Iodine-131	Diagnose and treat thyroid disorders
Iridium-192	Test integrity of pipeline welds, boilers, and aircraft parts
Thallium-201	Cardiology and for tumor detection
Xenon-133	Lung-ventilation and flood-flow studies

Source: Nuclear Regulatory Council

**Radioactivity Results
from an Imbalance of
Forces in the Nucleus**

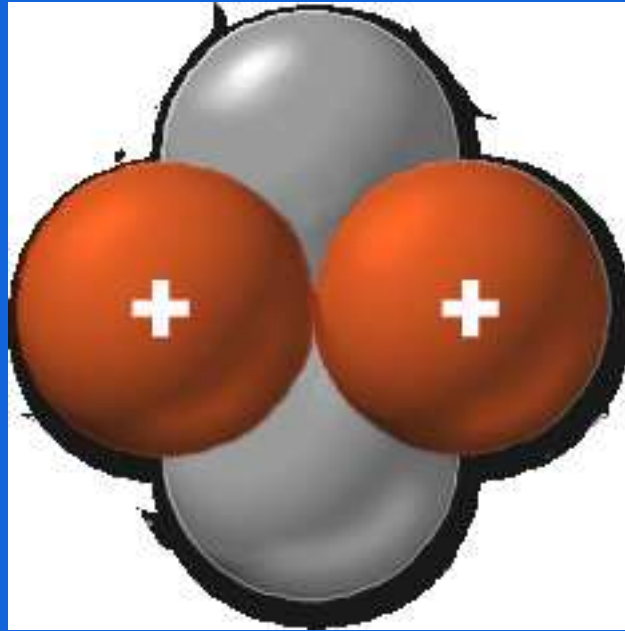

Helium nucleus

Strong Nuclear Force

***An attractive force that
acts between all
nucleons***

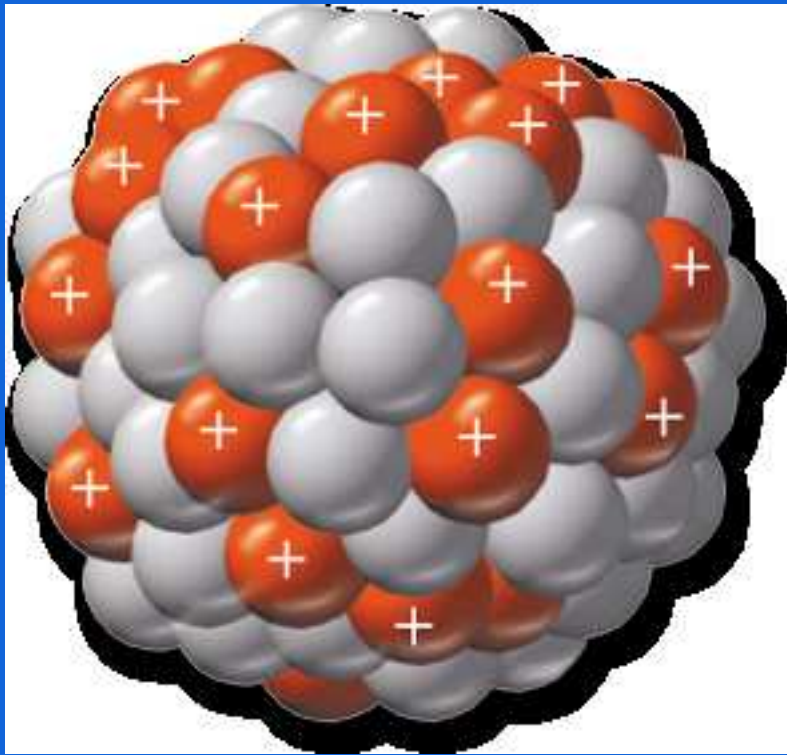

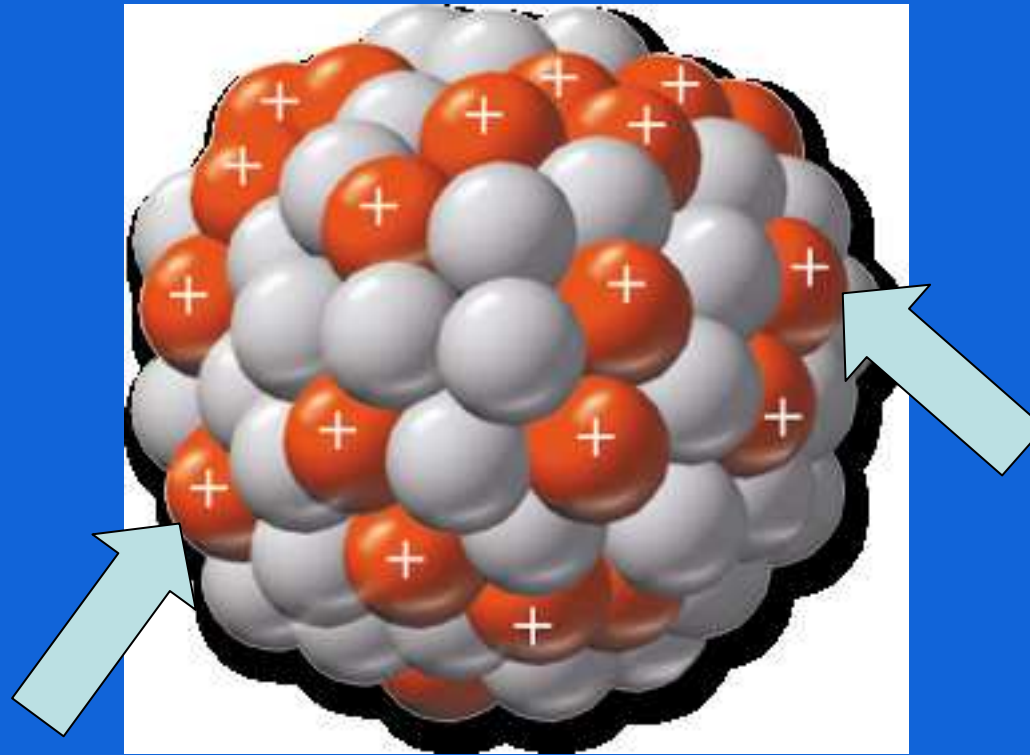

These protons are not normally attracted to each other

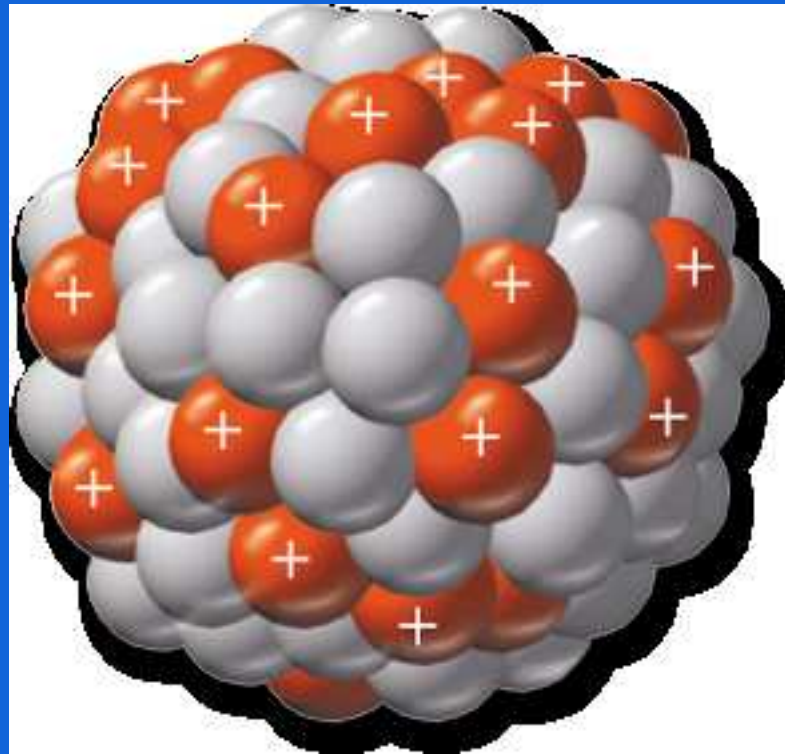

***Neutrons are needed to
create the strong
nuclear force***

***There is a limit to the
number of neutrons
that can be added to
an atomic nucleus...***

***...neutrons need to
have protons around
them in order to
remain stable...***

***...with too many
neutrons, and not
enough protons,
something most
bizarre occurs...***



A lone neutron....











...converts to a proton!













Proton to Neutron ratios

Proton to Neutron ratios

Optimum 1 to 1

Proton to Neutron ratios

Optimum ***1 to 1***

Limit ***1 to 1.4***

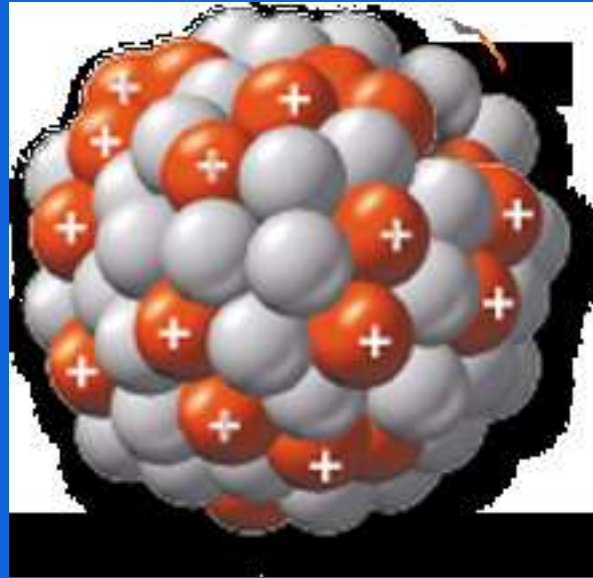

A nucleus with “too many neutrons”

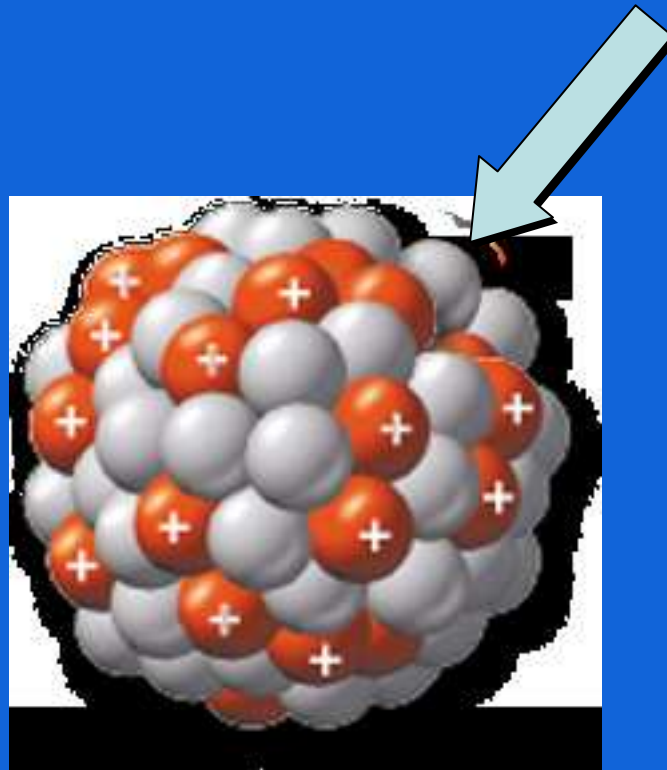

A nucleus with “too many neutrons”

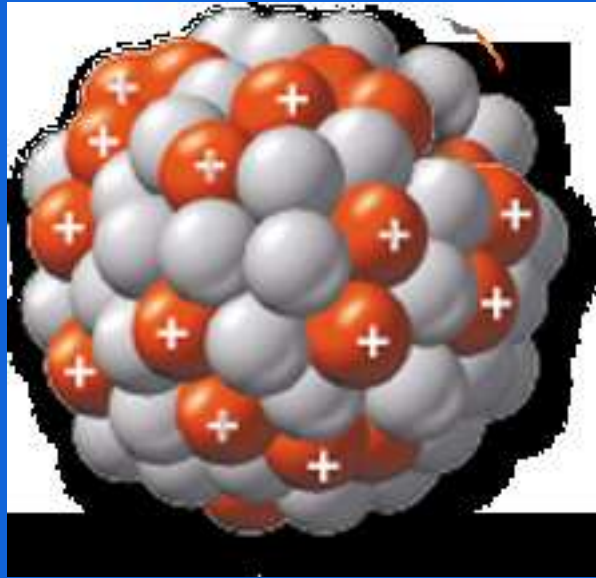









Hmm...extra proton?

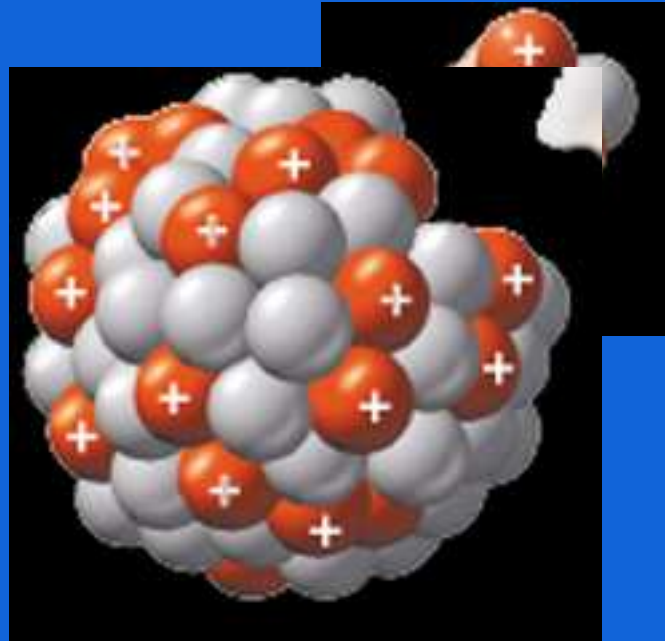





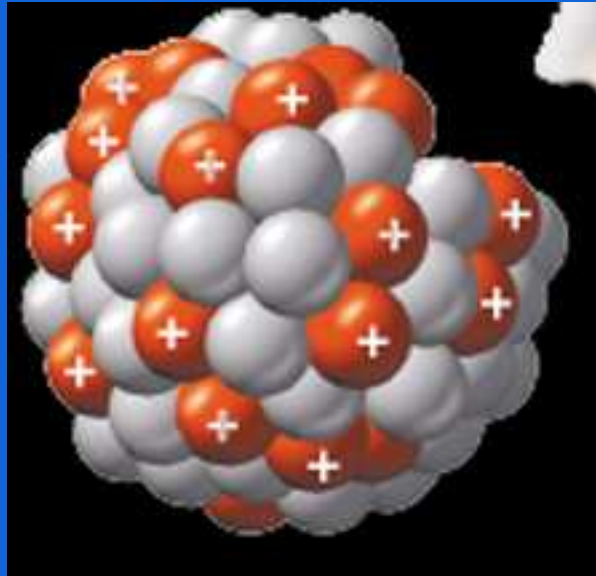

The size of the nucleus is limited

- 1) The nucleus cannot hold a very large number of protons together.***
- 2) There cannot be an unlimited number of neutrons.***

**A Radioactive Element
Can Transmute to a
Different Element**

Transmutation

***The changing of one
element to another***

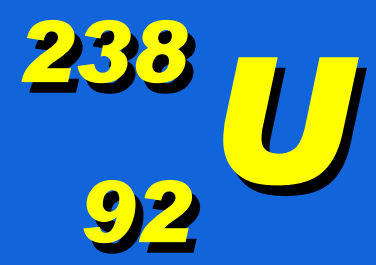
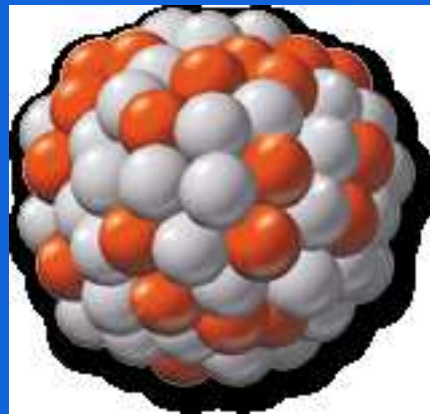

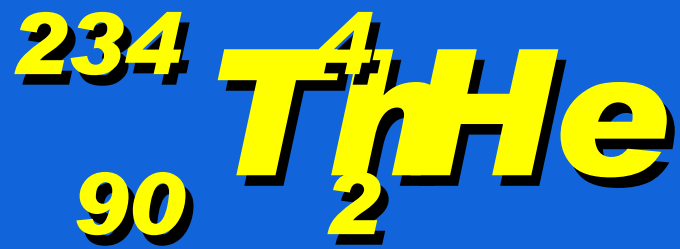
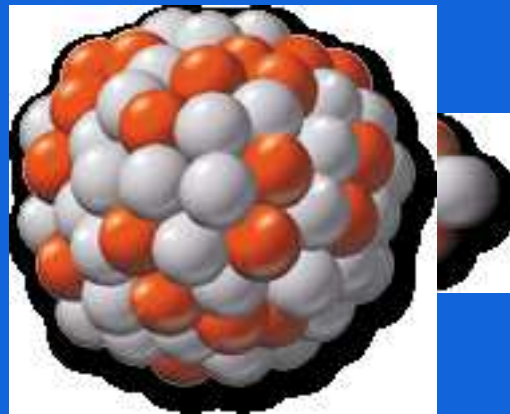

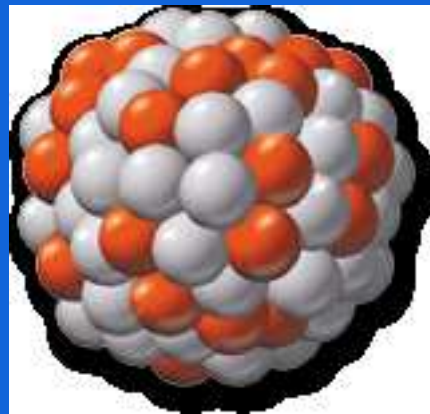

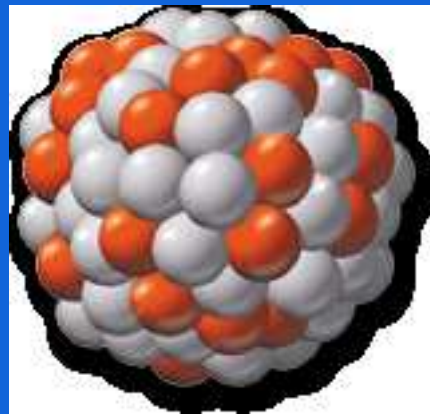

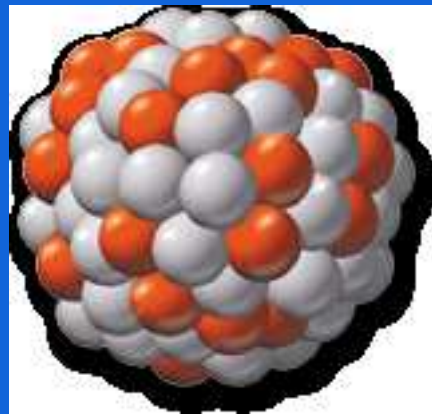

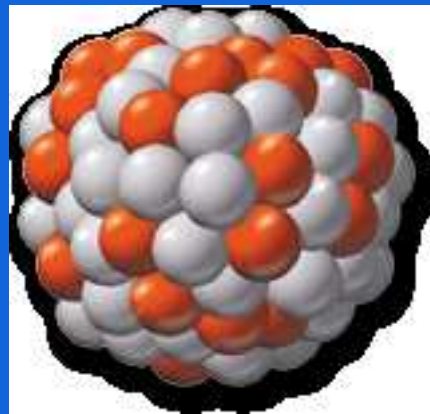

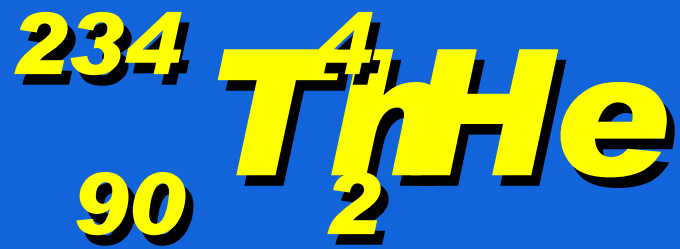
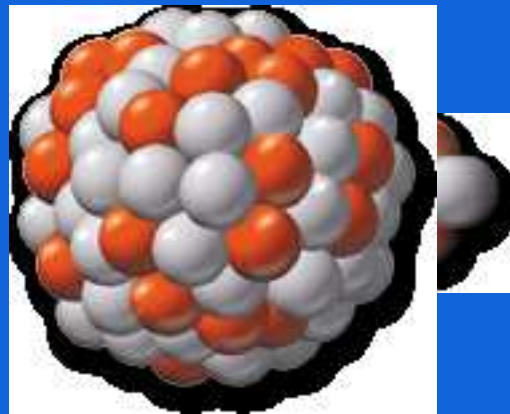

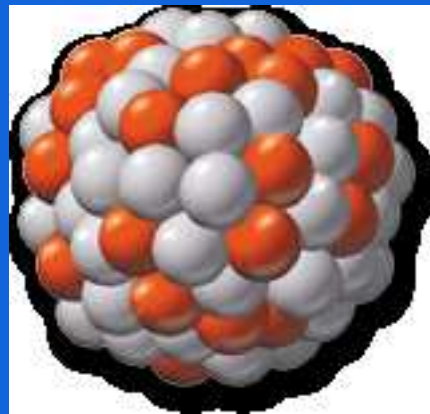

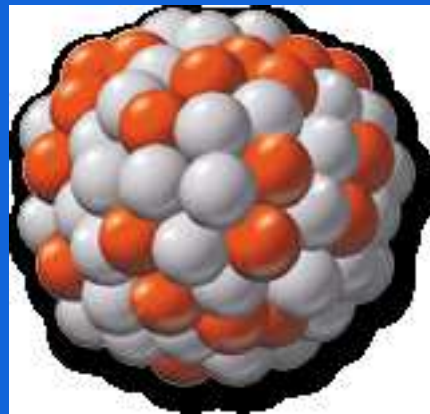

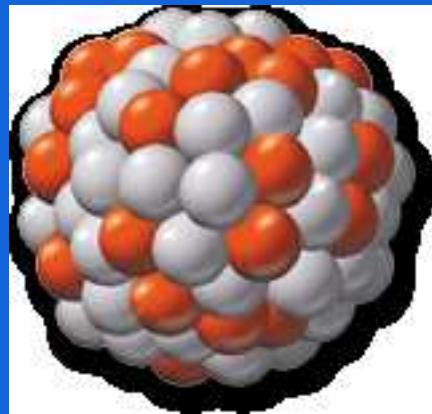

$^{234}_{90}\text{Th}$

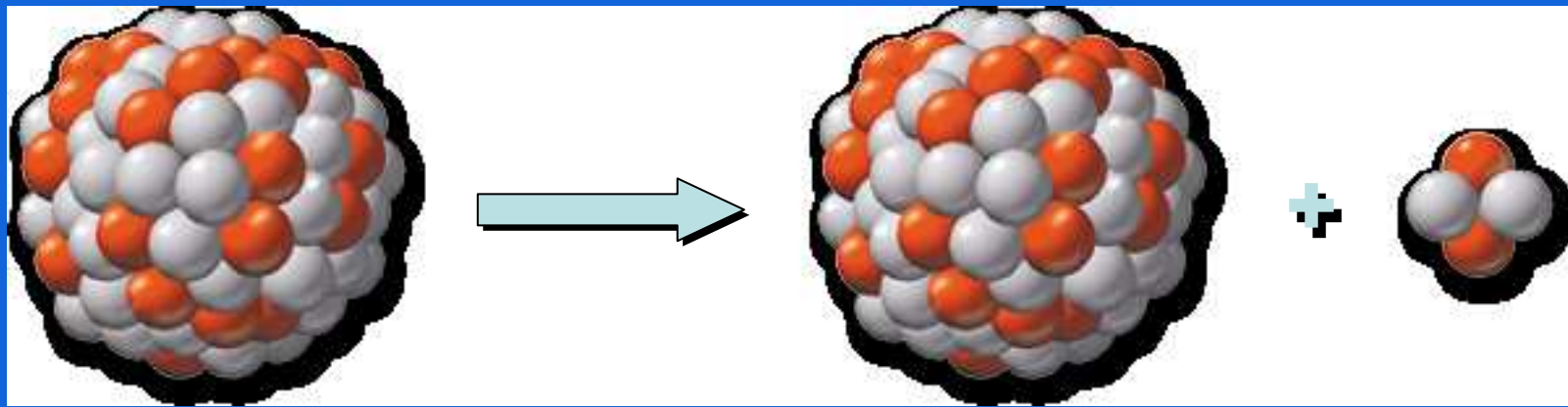

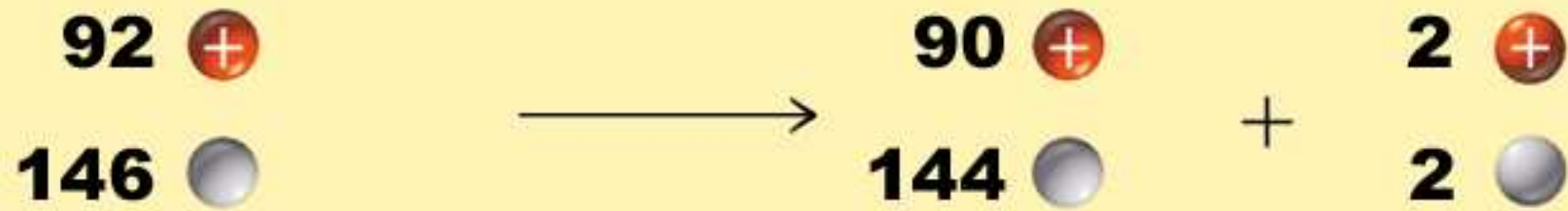
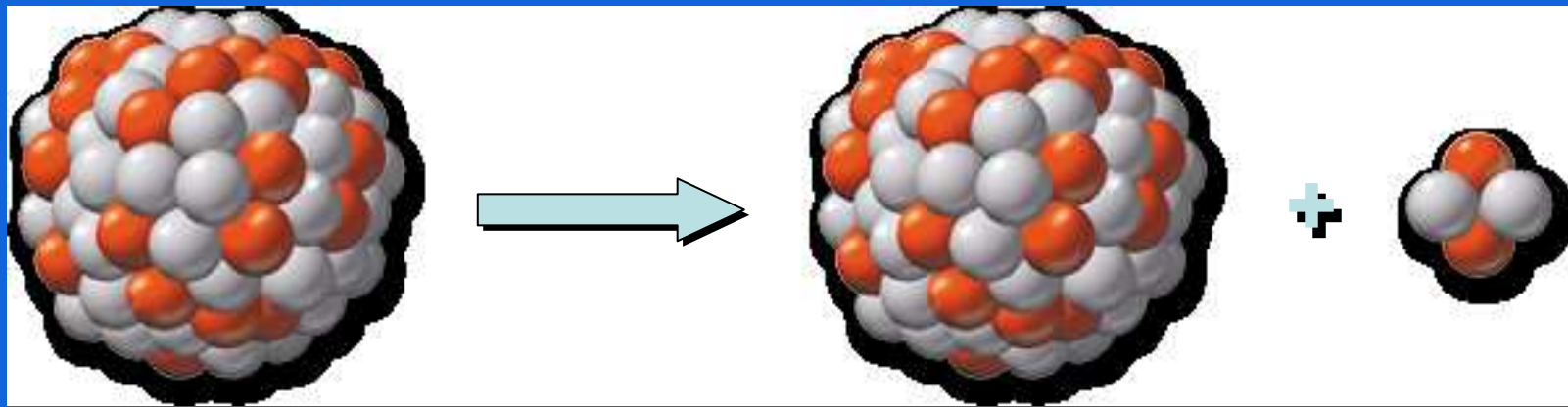

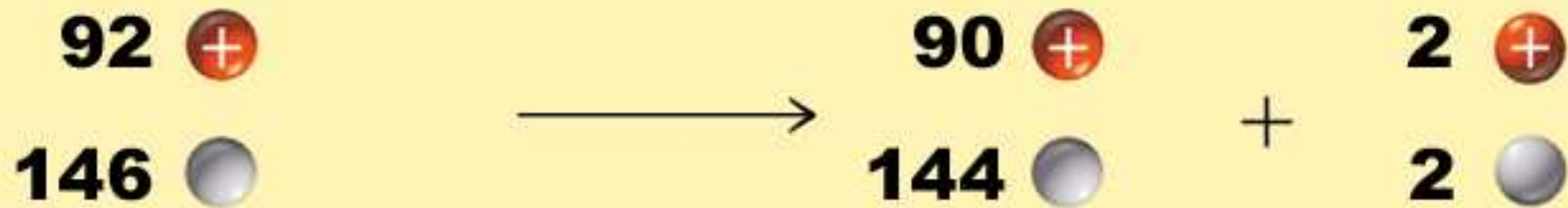
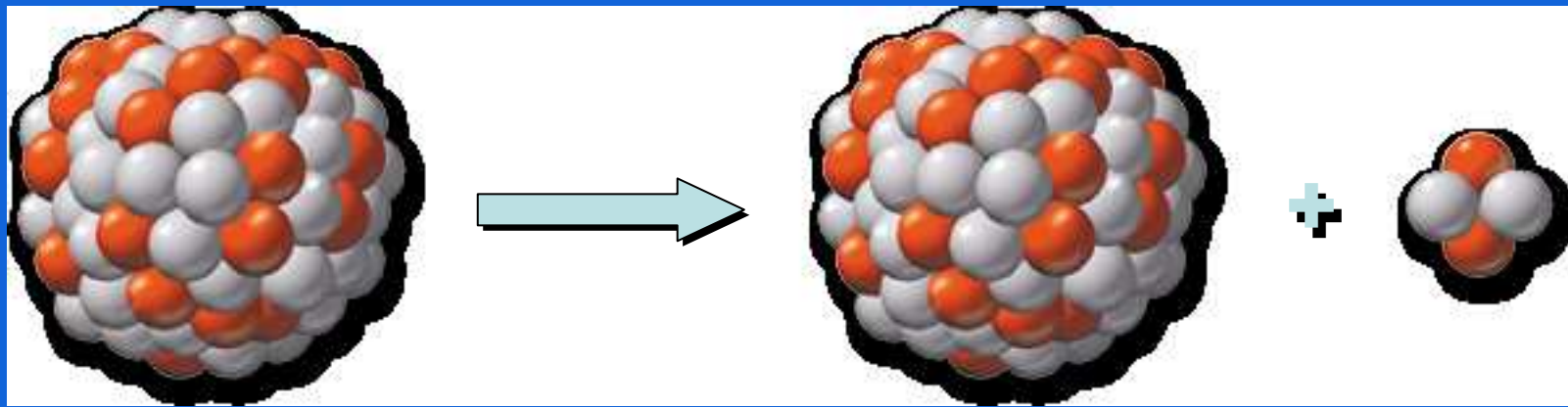

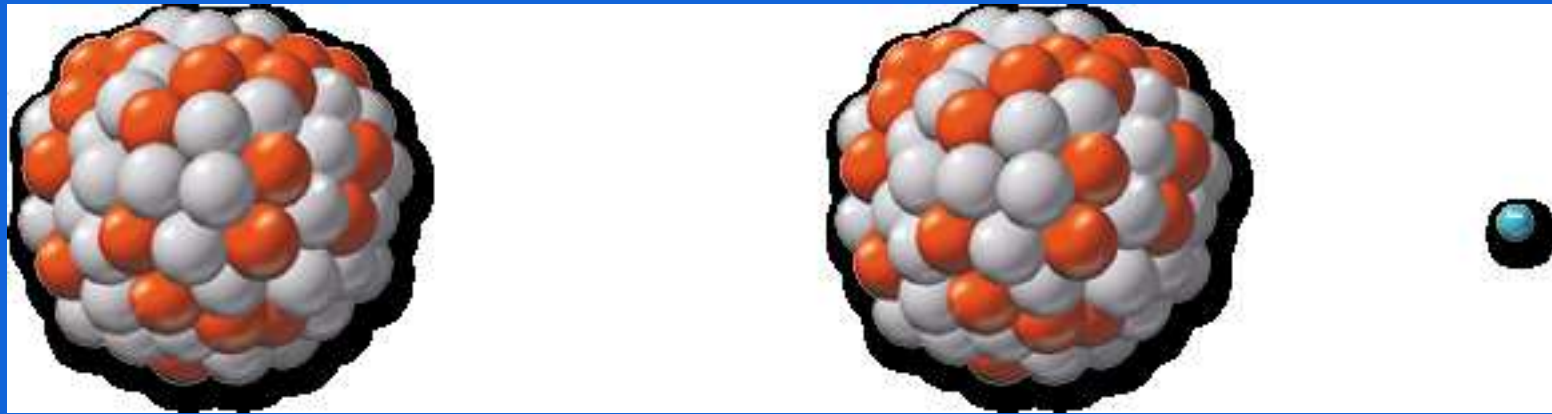

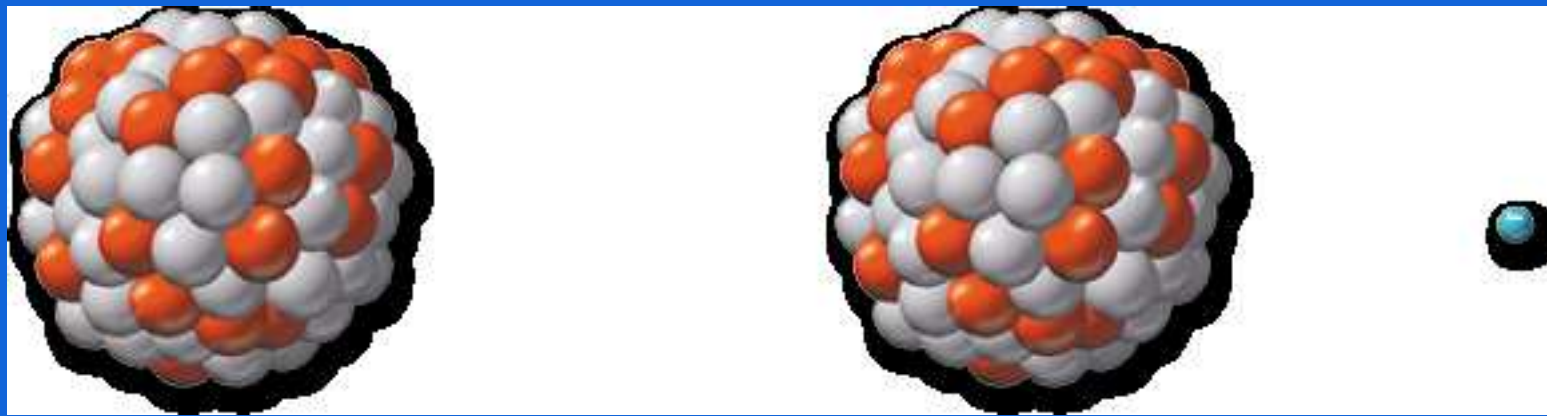

90 

144 



91 

143 

+

1 

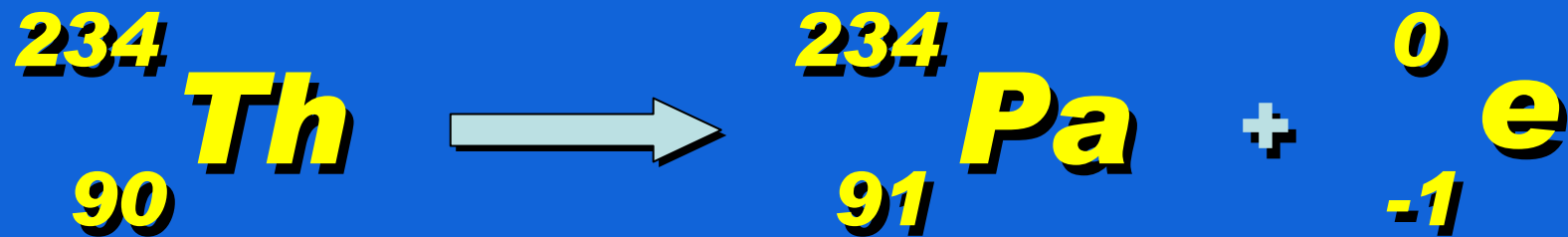
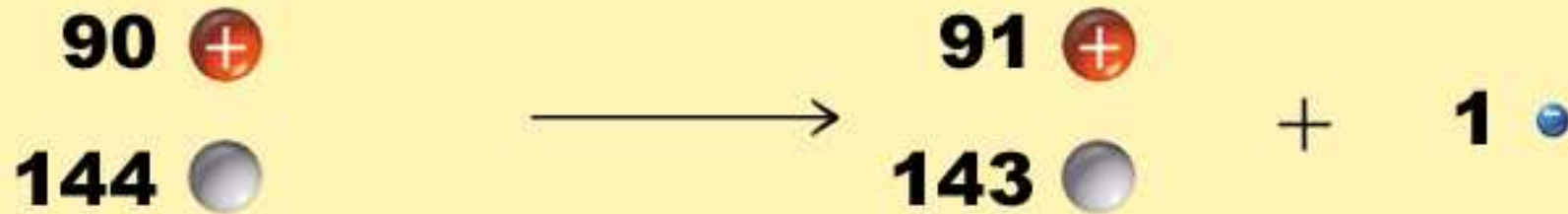
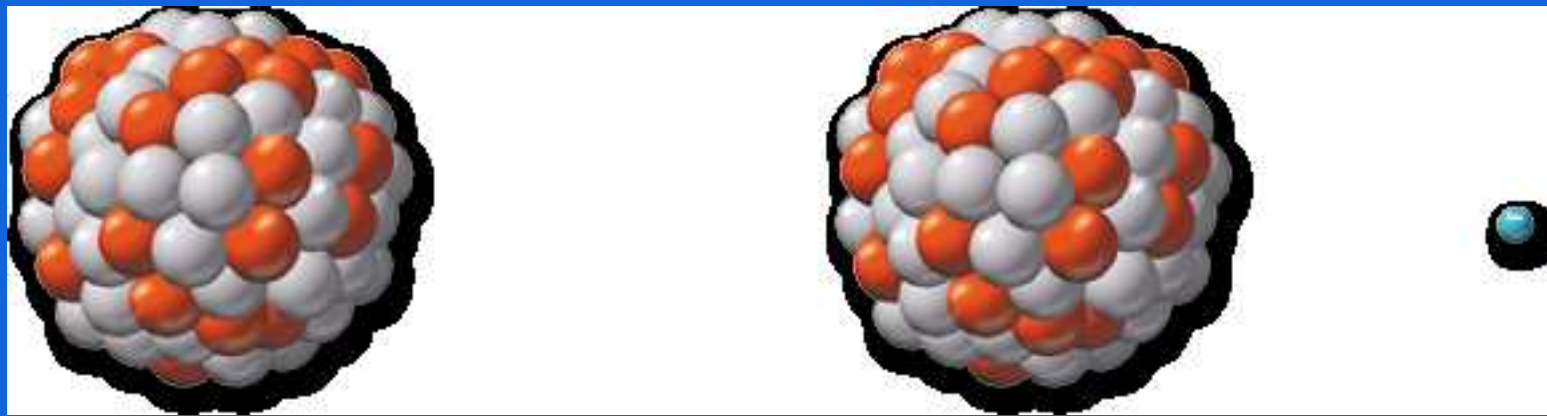

Radioactive Half-Life

***The time it takes for
one-half of a radioactive
sample to decay***

Element

Half-Life

Uranium-238

4.5 x 10⁹ years

Element

Half-Life

Uranium-238

4.5 x 10⁹ years

Carbon-14

5730 years

Element

Half-Life

Uranium-238

4.5 x 10⁹ years

Carbon-14

5730 years

Bismuth-210

5.0 days

Element

Half-Life

Uranium-238

4.5 x 10⁹ years

Carbon-14

5730 years

Bismuth-210

5.0 days

Polonium-214

1.6 x 10⁻⁴ sec

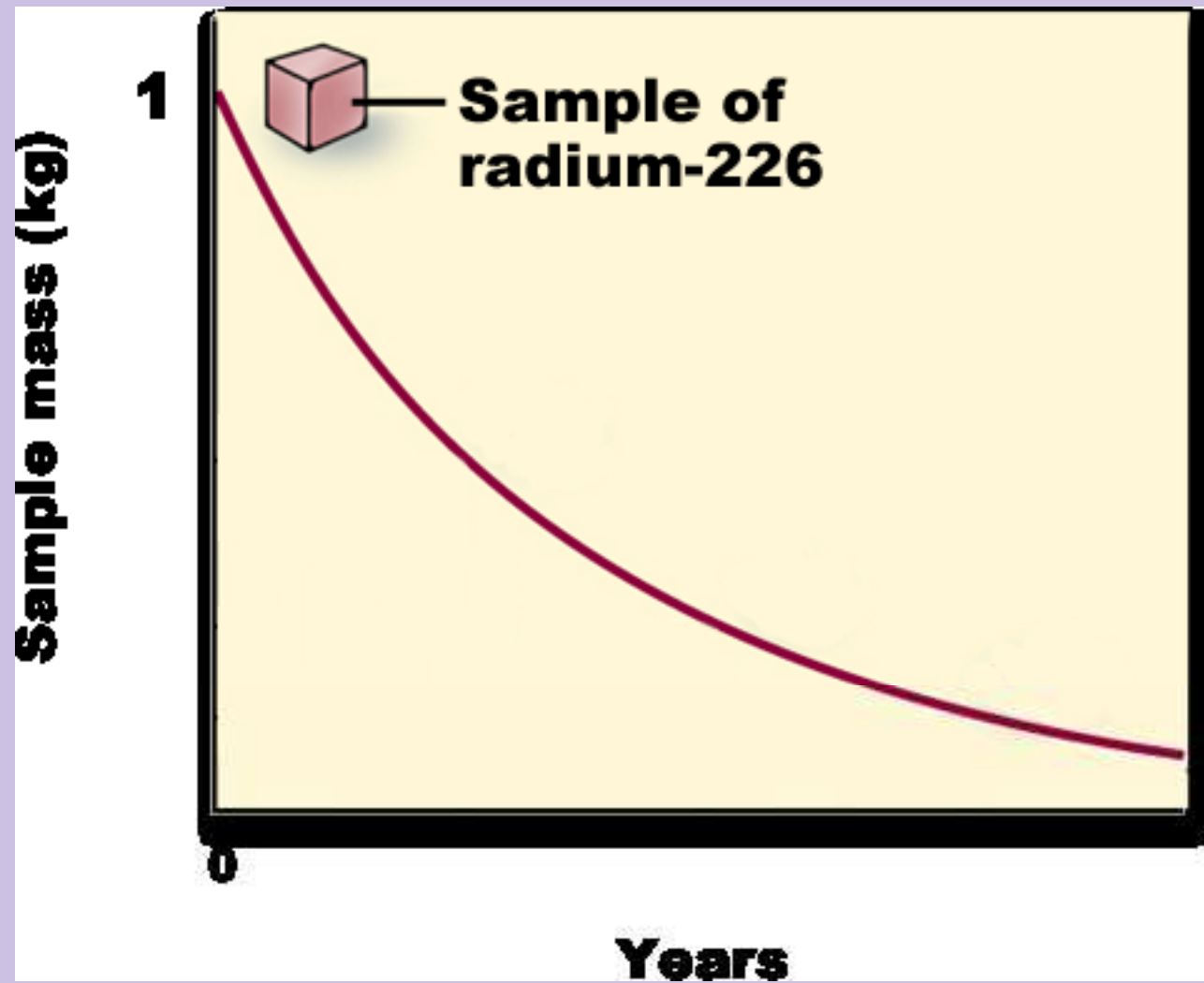

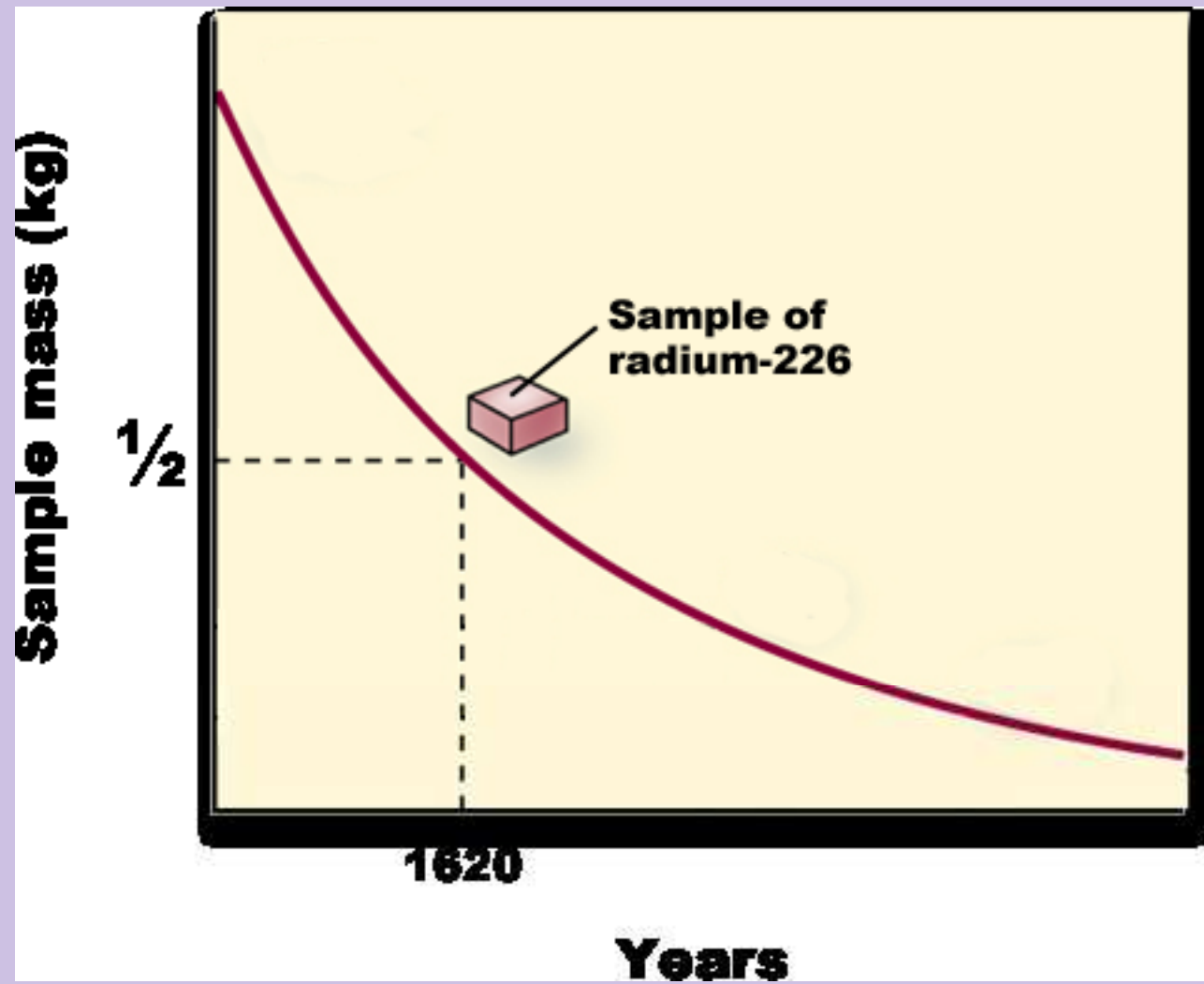

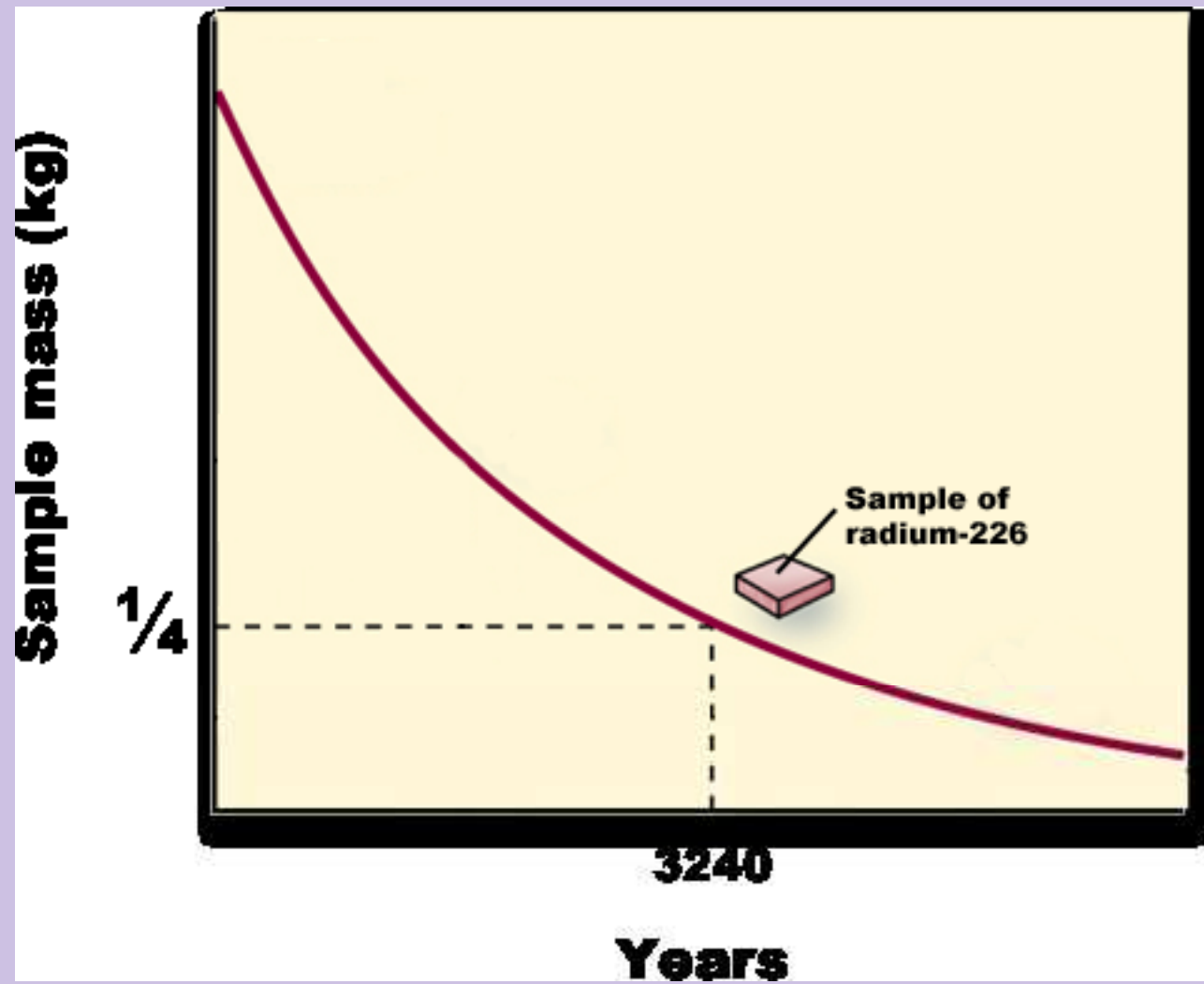

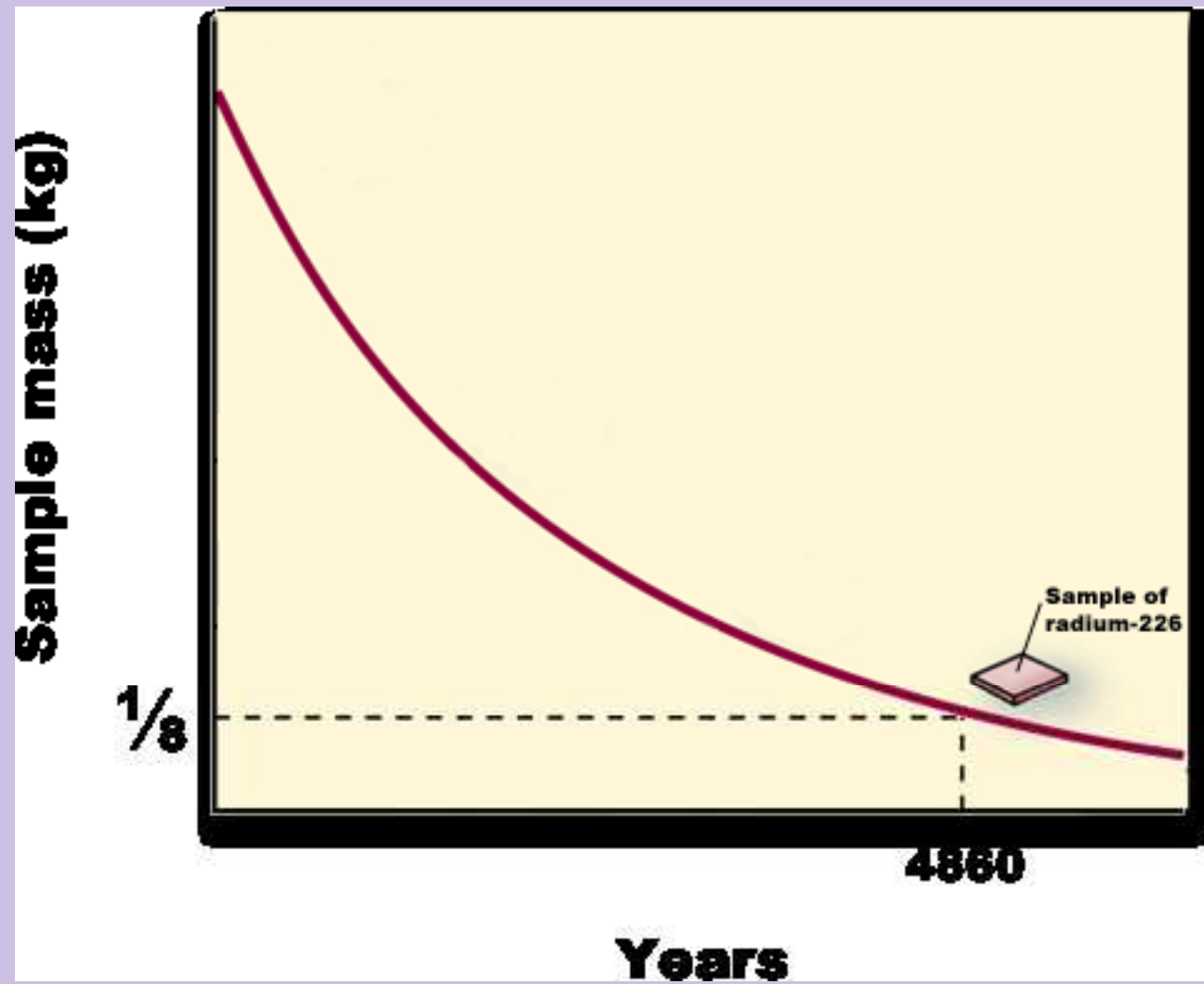

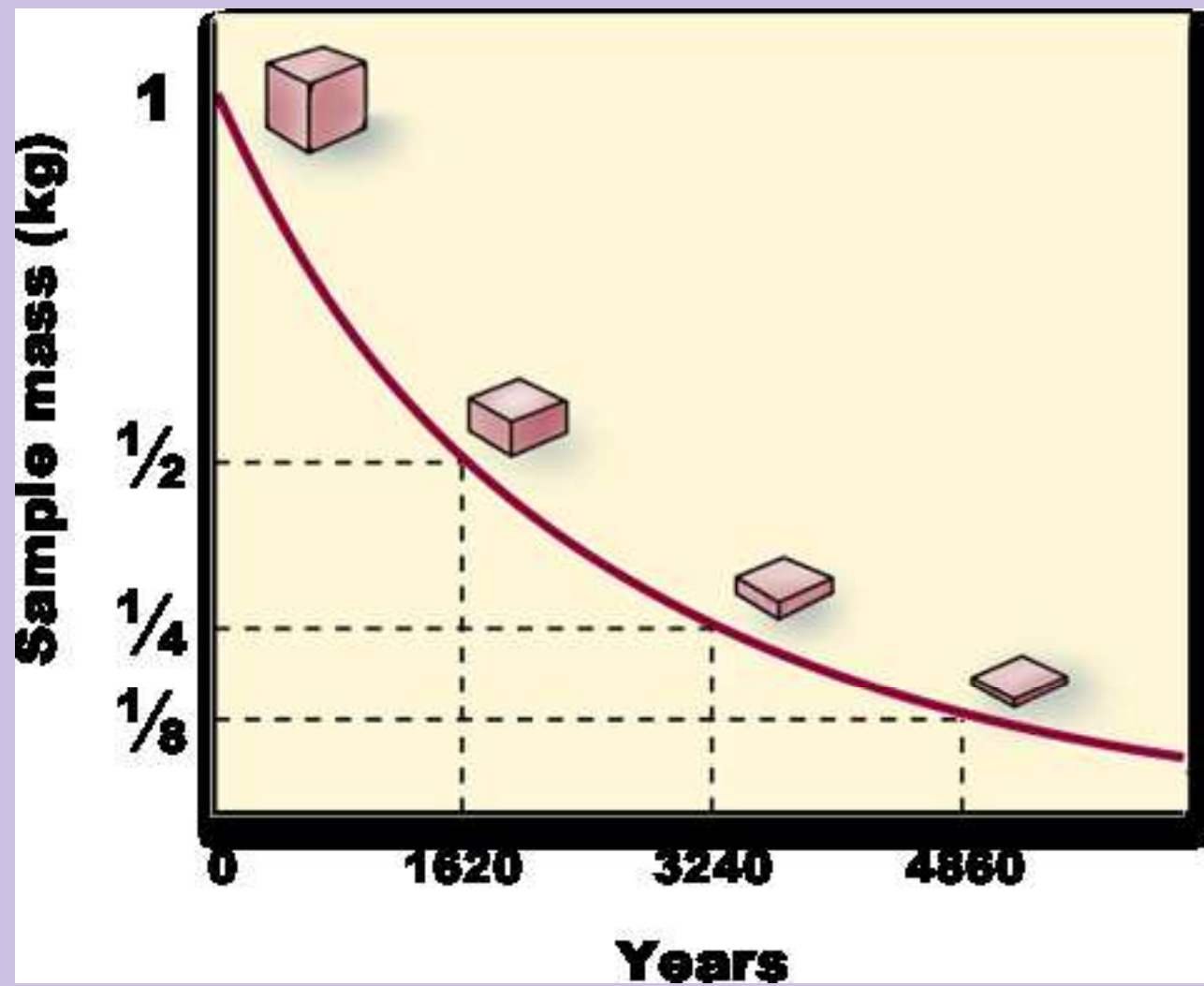

Radioactive Half-Life

The time it takes for one-half of a radioactive sample to decay

Look at factors of 2

One half-life ($1/2$)

Two half-lives ($1/4$)

Three half-lives ($1/8$)

For Example: A material has decreased by $1/4$ of its original amount it has gone through two half-lives





N-14





N-14

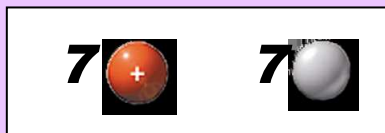



N-14





N-14



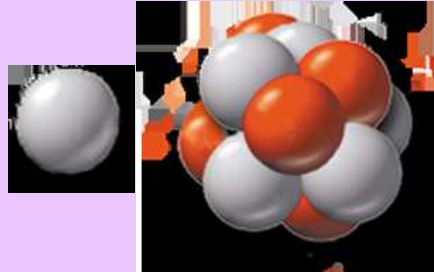

N-14



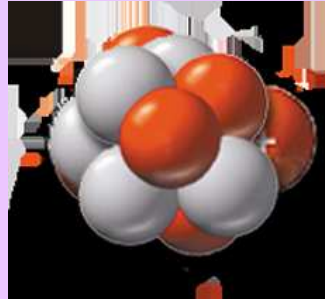

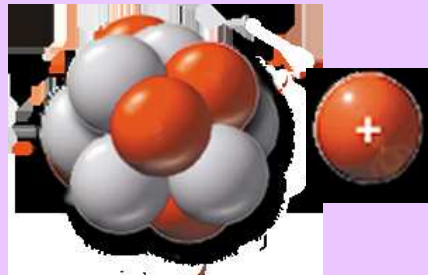

C-14





C-14





C-14





C-14





C-14

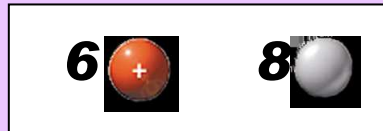



C-14





$^{14}\text{CO}_2$





$^{14}\text{CO}_2$

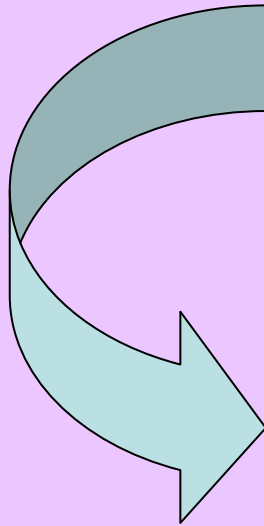

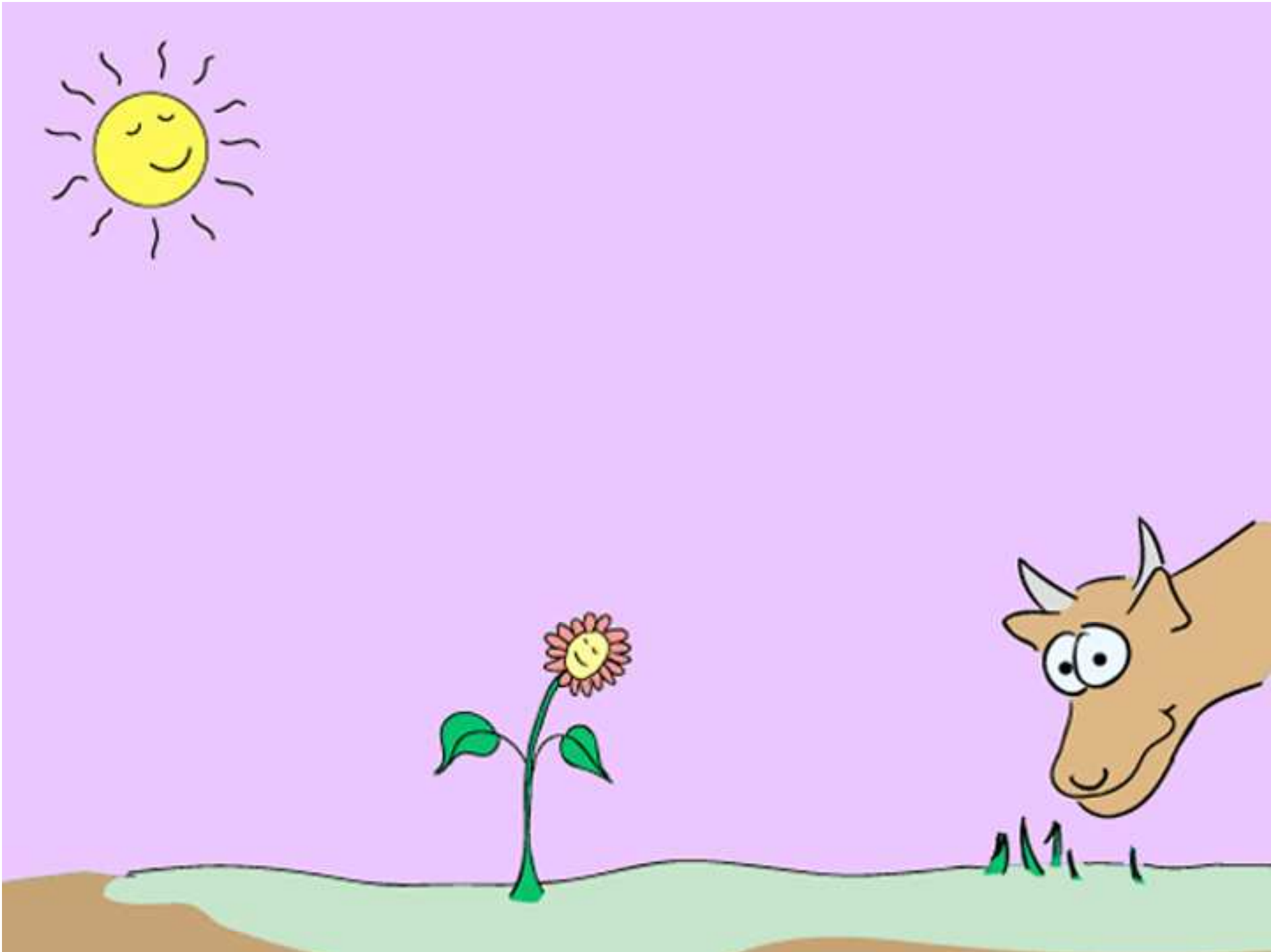

Carbon-14 is a radioactive isotope that is naturally incorporated from carbon dioxide into living organisms, the amount remains relatively constant during the life of the organism

When the living organisms dies the carbon 14 is no longer being replaced in the organism and will start to decay. The amount of loss from the that compared to living organisms can be used to determine when the organism died.

22,920 years ago



17,190 years ago



11,460 years ago



5730 years ago



Present





Calculate Age

Problem:

The carbon-14 radioactivity in the bones of a body was measured to be $1/8$ of that compared to a living person

How long ago did the person live?

Calculate Age

Calculation of Age:

The carbon-14 has decreased by $1/8$ which is three half lives ($1/2$ times $1/2$ times $1/2 = 1/8$)

Carbon-14 half life = 5730 years

3 times 5730 = 17,190 years

Present



***One Half-Life
5730 years ago***



Two Half-Lives
11,460 years ago



Three Half-Lives
17,190 years ago

